

1.3 Propagating Crops from Seed and Greenhouse Management

Introduction	3
Instructor's Lecture 1 Outline: Seed and Seedling Biology and Cultural Requirements	5
Detailed Lecture 1 Outline for Students	7
Instructor's Lecture 2 Outline: Propagation Media and Container Formats	11
Detailed Lecture 2 Outline for Students	15
Demonstration 1: Greenhouse Management	21
Instructor's Demonstration Outline	21
Demonstration 2: Propagation Media	23
Instructor's Demonstration Outline	23
Demonstration 3: Sowing Seed	25
Instructor's Demonstration Outline	26
Demonstration 4: Transplanting or "Pricking Out"	27
Instructor's Demonstration Outline	28
Demonstration 5: Irrigation in Propagation Facilities	29
Instructor's Demonstration Outline	29

Demonstration 6: Seedling Development and the “Hardening Off” Process	31
Instructor’s Demonstration Outline	31
Assessment Questions and Key	33
Resources	37
Glossary	39
Appendices	
1. Seed Viability Chart	41
2. Soil Temperature Conditions for Vegetable Seed Germination	42
3. Examples of Propagation Containers	43
4. Days Required for Seedling Emergence at Various Soil Temperatures	44
5. Approximate Monthly Temperatures for Best Growth and Quality of Vegetable Crops	45
6. Propagation Media— Ingredients and Properties Imparted	46
7. Sample Soil Mix Recipes	47
8. “Pricking Out” Technique, Depth of Planting	48
9. Flat-Grown and Cell-Grown Seedlings	49
10. Propagation and Crop Performance Records Sheet	50
11. Greenhouse Records Sheet	51

Introduction: Propagation/Greenhouse Management

UNIT OVERVIEW

Getting plants off to a healthy start is critical to successful crop production. This unit introduces students to the basic skills and concepts associated with the sexual propagation of crop plants. Beginning with seed and seedling biology, the first lecture introduces the cultural requirements and management practices involved in seed germination and seedling development. In the second lecture, the role and desirable characteristics of propagation media, the nature of specific soil mix ingredients, and the advantages and disadvantages of common container formats will be covered. The types of plants that are typically sexually propagated will be addressed, along with the rationale and associated costs and benefits of both passive-solar and conventional greenhouse structures. General guidelines and current resources to manage common greenhouse pests and pathogens are also reviewed. A series of demonstrations then introduces the skills involved in sowing seeds and the cultural practices used to manage passive solar greenhouses to promote successful development of organically grown seedlings.

MODES OF INSTRUCTION

- > LECTURE (2 LECTURES, 2 HOURS EACH)
Lecture 1 covers seed biology, and the cultural requirements for germination. Lecture 2 addresses desirable characteristics of propagation media, common container formats, types of plants that are sexually propagated, the rationale and associated costs and benefits of solar and conventional greenhouse structures, and the prevention/management of common greenhouse pest and pathogens.
- > DEMONSTRATION 1: GREENHOUSE MANAGEMENT (1–1.5 HOURS)
The greenhouse demonstration illustrates the way that air temperature, soil moisture, and air circulation are managed to create optimal environmental conditions for seed germination and seedling growth. Students will also be introduced to the steps used to prepare seedlings for field transplanting.
- > DEMONSTRATIONS 2–6: PROPAGATION MEDIA, SEED SOWING, TRANSPLANTING, IRRIGATION, AND SEEDLING DEVELOPMENT (1–1.5 HOURS EACH)
The propagation demonstrations illustrate the techniques used to produce propagation media, sow seeds, transplant seedlings, and manage irrigation and seedling development.
- > ASSESSMENT QUESTIONS (0.5–1 HOUR)
Assessment questions reinforce key unit concepts and skills.

LEARNING OBJECTIVES

CONCEPTS

- Definition of sexual propagation
- Propagation media: Components, properties and ratios of materials used
- Containers: Advantages and disadvantages of commonly used formats
- Accurate documentation of propagules for trouble shooting
- Germination requirements of various crops: Seed physiology, seed treatments, temperature ranges, light, air circulation, and moisture conditions
- Physiological process of seed germination and seedling development, and its relationship to environmental conditions
- Optimal conditions for early stages of plant growth up to transplanting stage, including the hardening off process and movement of plants through facilities
- The role, timing, and tools used in supplemental fertilization
- Preventive and active pest and pathogen management

SKILLS

- How to create propagation media
- How to sow seeds into flats and cell trays
- How to manage a greenhouse/cold frame: Maintaining optimal environmental conditions for germination and early stages of seedling growth
- How to transplant/“prick out” seedlings
- How to manage seedlings in preparation for field transplanting
- How to identify appropriate life stage for transplanting to field/garden
- When and how to deliver supplemental fertilization
- How to manage pests and pathogens: Monitoring, identification resources, and active management

Lecture 1 Outline: Seed and Seedling Biology and Cultural Requirements

for the instructor

A. Pre-Assessment Questions

1. What conditions must be met for a seed to successfully germinate and grow into a viable seedling?
2. What are the advantages of propagating annual vegetables in a greenhouse or similar climate control structure compared to direct seeding crops?
3. Describe the optimal environmental conditions for the germination and growth of annual vegetables.
4. What are the characteristics of seedlings when ready for transplanting to the field or garden? What actions may growers take to prepare seedlings for transplanting into the garden or field?
5. What is the most effective way to manage/prevent the development of pest and diseases in a propagation facility? Where would you seek information to identify pests or pathogens and to find Organic Materials Review Institute- (OMRI-)/National Organic Program-certified active control options if pest and or diseases should affect your seedlings?

B. Sexual Propagation

1. Definition of sexual propagation
2. Types of plants grown from seed
 - a) Annuals
 - b) Biennials
 - c) Perennials
3. Characteristics of open pollinated and hybrid seed
 - a) Open pollinated seed results in offspring closely resembling the previous generation
 - i. Self-pollinated populations
 - ii. Cross-pollinated populations
 - iii. Advantages:
 - iv. Disadvantages:
 - b) Hybrid seeds are the product of cross pollination of two different, but homogeneous inbred, stable lines
 - i. Advantages:
 - ii. Disadvantages:

C. Seed Germination and Early Seedling Development

1. Necessary preconditions for seed germination
 - a) Viability
 - b) Physical, chemical dormancy factors must be broken
 - i. Physical dormancy (hard, thick seed coats): Can be broken by soaking, scarifying, exposure to soil microorganisms, depending on species needs

- ii. Chemical dormancy: Internal chemical/metabolic conditions that prevent seed germination until appropriate environmental conditions have been met through leaching, cold/moist stratification, fire scarification, depending on species needs
- 2. Environmental factors involved in germination
 - a) Temperature
 - b) Moisture
 - c) Aeration
 - d) Light
- 3. Physiological steps in germination
 - a) Phase I: Imbibation
 - b) Phase II: Interim or lag phase
 - c) Phase III: Root radical emergence
- 4. Early seedling development
 - a) Continued division-extension of root radical
 - b) Emergence of plumule or growing point of the shoot
 - c) Seedling weight increases, storage tissue weight decreases
 - d) Respiration and water uptake increase
 - e) Development of branched root system
 - f) Development of true leaves

D. Management of Environmental Conditions During Germination, Development, and Seedling Maturation

- 1. Use of propagation structures/infrastructure to optimize environmental conditions during germination
 - a) Temperatures
 - b) Air circulation
 - c) Moisture delivery
- 2. Continued management of environmental conditions for seedling development
 - a) Temperature management remains critical
 - b) Maintenance of good air circulation continues
 - c) Moisture delivery
 - d) Availability of light for photosynthesis
- 3. Seedling maturation, or hardening off through exposure to outdoor growing conditions
 - a) Day/night temperature fluctuation
 - b) No buffering from natural air circulation or prevailing wind patterns
 - c) Moisture delivery: Decrease in frequency but increase in depth/volume
 - d) Exposure to sunlight conditions comparable to field conditions

Detailed Lecture 1 Outline: Seed and Seedling Biology and Cultural Requirements

for students

A. Pre-Assessment Questions

1. What conditions must be met for a seed to successfully germinate and grow into a viable seedling?
2. What are the advantages of propagating annual vegetables in a greenhouse or similar climate control structure compared to direct seeding crops?
3. Describe the optimum environmental conditions for the germination and growth of annual vegetables.
4. What are the characteristics of seedlings when ready for transplanting to the field or garden? What actions may growers take to prepare seedlings for transplanting into the garden or field?
5. What is the most effective way to manage/prevent the development of pest and diseases in a propagation facility? Where would you seek information to identify pests or pathogens and to find Organic Materials Review Institute- (OMRI-)/National Organic Program-certified active control options if pest and/or diseases should affect your seedlings?

B. Sexual Propagation

1. Definition: The intentional reproduction of a new generation of plants by the germination and growth of seeds that were created in the previous generation through the fertilization of a plant ovary via the union of male and female sex cells. Results in a genetically unique plant generation.
2. Types of plants grown from seed
 - a) Annuals: Plants that germinate, grow vegetatively, flower, and produce seeds all within a single year. Sexual propagation is the only practical means of propagation.
 - b) Biennials: Plants completing their entire life cycle within two years. Growth is primarily vegetative in year one. In year two growth is directed primarily toward reproduction in response to vernalization, photoperiod, etc. Propagation by seed is the only practical means of reproducing biennial crops.
 - c) Perennials: Plants that live more than two years. Beyond the juvenile life phase, perennials grow vegetatively, flower, and produce seeds every year. The life span: three to thousands of years. Can be grown from seed. Many are reproduced asexually/vegetatively to hasten maturity, maintain genetic uniformity, and therefore retain desired morphological characteristics.
3. Characteristics of open-pollinated and hybrid seed
 - a) Open-pollinated seed: Produced when a parent plant is fertilized by another member of the same genetically stable population. Offspring bear traits or qualities that closely resemble the parent population. These seeds may come from:
 - i. Self-pollinated populations, normally of a stable homozygous genetic makeup, thus limiting problems associated with inbreeding depression
 - ii. Cross-pollinated populations, of typically heterozygous genetic makeup, which maintain their vigor and adaptability through the sharing of genetic information within a stable population

- iii. Advantages: Genetic diversity within a population provides degree of naturally occurring resistance to pathogens, climate shifts, etc. With appropriate isolation distances and population sizes, seed can be easily and inexpensively produced/saved.
 - iv. Disadvantages: In certain species uniformity, yield, overall performance may not match that of hybrid varieties
- b) Hybrid seeds: The product of cross pollination of two different, but homogeneous inbred, stable lines, each of which contribute desirable characteristics to the subsequent generation. Seeds saved from this next generation typically possess a highly heterogeneous nature and will produce offspring unlike the hybrid parent population.
- i. Advantages: Uniform characteristics throughout population (flavor, yield, pest-disease resistance, fruit quality, etc.)
 - ii. Disadvantages: Complex breeding process makes it difficult for growers to produce and save their own hybrid seeds. Though often selected for disease resistance, the genetic uniformity of a hybrid population can make them susceptible to unexpected pathogens.

C. Seed Germination and Early Seedling Development

1. Necessary preconditions for seed germination
 - a) Viability: Seeds must contain living, healthy embryonic tissue capable of germination (see appendix 1, Seed Viability Chart)
 - b) When present, physical and chemical dormancy factors must be broken to facilitate germination
 - i. Physical dormancy (e.g., hard, thick seed coats): Can be broken by soaking, scarifying, exposure to soil microorganisms. Methods are species specific. (See Resources section for guides to propagation techniques.)
 - ii. Chemical dormancy: Growers replicate natural processes and environmental conditions to break internal chemical/metabolic conditions preventing seed germination (e.g., leaching, cold/moist stratification, fire scarification, etc.)
2. Environmental factors involved in germination
 - a) Temperature: All seeds have maximum-minimum and optimal temperature range within which germination is possible (see appendix 2, Soil Temperature Conditions for Vegetable Seed Germination)
 - i. Minimum: Lowest temperature at which seeds can effectively germinate
 - ii. Maximum: The highest temperature at which germination can occur. Above this threshold, injury or dormancy are often induced.
 - iii. Optimal temperature: The range in which germination occurs most rapidly and uniformly (see appendix 2)
 - b) Moisture: All seeds require available moisture, delivered through the soil media by capillary action, to initiate internal metabolic processes leading to germination. Field soil or propagation media should retain adequate moisture (~50%–75% of field capacity) and be of a firm, fine texture to provide good seed-to-soil contact.
 - c) Aeration: Soil/media must allow for gas exchange to and from the germinating embryo
 - i. Oxygen is required in the soil media to facilitate embryonic respiration
 - ii. Carbon dioxide, a byproduct of respiration, must be able to dissipate and move away from the seed
 - iii. Limitations on gas exchange can result from structural characteristics of the media and from poor cultural practices, especially excess moisture delivery

- d) Light
 - i. Seeds of certain species (e. g., Begonia, Primula, Coleus) require exposure to light to induce germination
 - ii. Most species germinate best under dark conditions, and in some cases (e.g., Phacelia, Allium, Phlox) germination may be inhibited by light
 - iii. Light in regards to germination requirements should not be confused with necessity of light for seedling development. All seedlings require sunlight of varying intensities for photosynthesis.
- 3. Physiological steps in germination: A three-phase process
 - a) Phase 1: Imbibation. Rapid initial uptake of water by the dry seed, softening, swelling of the seed coat.
 - b) Phase 2: Interim or lag phase. Water uptake greatly reduced while internal physiological processes begin.
 - i. Activation of mitochondria: Supporting cellular respiration
 - ii. Protein synthesis: Translation of stored RNA
 - iii. Metabolism of stored reserves to fuel development
 - iv. Enzyme production-synthesis: Loosening of cell walls
 - c) Phase 3: Root radical emergence. Initially results from cell enlargement, but soon followed by elongation of radical and cell division.
- 4. Early seedling development
 - a) Continued division-extension of root radical from base of embryo axis, and
 - b) Emergence of plumule or growing point of the shoot, from upper end of the embryo axis. Initial seedling growth follows one of two patterns, either:
 - i. Epigeous germination: Elongation of the hypocotyl, raising the cotyledons above ground where they become involved in photosynthesis, or
 - ii. Hypogeous germination: The hypocotyl does not continue to expand, and only the epicotyl emerges above ground, the cotyledons eventually ceasing involvement in metabolic activities
 - c) Overall weight of seedling increases, while weight of storage tissue decreases
 - d) Rate of respiration and water uptake steadily increases with continued cell division and elongation of roots and above-ground shoots
 - e) Development of branched root system, with continued division/elongation; root systems, except those exclusively taprooted, naturally branch, increasing surface area for uptake of water and nutrients from soil media
 - f) Development of true leaves, roughly concurrent with development of branched root system in most species, begins process of effective photosynthesis, helping to fuel continued growth

D. Management of Environmental Conditions to Optimize Germination, Seedling Development, and Seedling Maturation

- 1. Optimizing germination: Propagation structures used to manage for optimal environmental conditions (e.g., temperature, air circulation, light, and soil medium moisture)
 - a) Critical to maintain temperatures within appropriate range for chosen crops (see appendix 2)
 - b) Critical to promote adequate air circulation to mitigate against presence of fungal pathogens/"damping off" organisms
 - c) With recently sown seed and germinating seedlings, moisture delivery is typically frequent and shallow. This prevents desiccation of imbibed seeds and emerging root radicals.

2. Seedling development: Management of temperature and moisture conditions often changes from seed to seedling. Plants are often moved to alternative structures (e.g., greenhouse to hoop houses) in response to their expanding range of physiological tolerance.
 - a) Temperature management remains critical, especially when trying to extend seasonal parameters. Note: Optimal temperatures for germination and subsequent growth may differ (e.g., Brassicas) (contrast appendix 2 with appendix 5, Approximate Monthly Temperatures for Best Growth and Quality of Vegetable Crops).
 - b) Maintenance of good air circulation continues to be important to prevent disease and promote strong structural/cellular development
 - c) Moisture delivery during seedling development typically begins to decrease in frequency but increase in depth to accommodate developing root system and leaf canopy, and thus increases in transpiration rate
 - d) Availability of light for photosynthesis to manufacture nutrients and promote strong cellular growth becomes of critical importance
3. Seedling maturation and hardening off: The final step prior to transplanting. Over three days (minimum) to two weeks, seedlings are gradually exposed to conditions that most closely resemble those of the field. This process decreases the likelihood of transplant shock and promotes the accumulation of carbohydrate nutrient reserves and continued strengthening of cell walls via:
 - a) Exposure to natural day-night temperature fluctuation, promoting carbohydrate reserve buildup
 - b) Little or no buffering from natural air circulation or prevailing wind patterns, thus promoting thickening of cell walls
 - c) Moisture delivery continues to decrease in frequency but increase in depth/volume relative to specific needs of species and container type to promote maximum root development and tolerance of moisture stress
 - d) Exposure to light should also be equivalent to field conditions to build plant strength and decrease likelihood of transplant shock

Lecture 2 Outline: Propagation Facilities, Media, and Container Formats

for the instructor

A. Propagation Facilities

1. Advantages of propagation facilities
 - a) Ability to control/modify environment (air temperature, air circulation, moisture of propagation media)
 - b) Environmental control and idealized conditions, season extension
 - c) Transplants and efficiency with seed and other resources
2. Disadvantages of propagation facilities
 - a) Added costs for infrastructure, containers, and soil media
 - b) Added labor and skills necessary
 - c) Not practical for all crops
 - d) More total days of growth
 - e) Density-concentration and risk of crop loss/damage due to pests, pathogens
 - f) Greater reliance on nonrenewable resources/materials
3. Types of propagation facilities and how environmental control is achieved
 - a) Enclosed automated greenhouses: Precise control achievable
 - i. Regulation of temperatures/air circulation by passive and active means
 - ii. Microclimatic heating
 - iii. Moisture regulation
 - iv. Solar radiation and thermal mass
 - b) Passive solar greenhouse: Good control possible
 - i. Solar radiation and thermal mass
 - ii. Use of venting systems to manage temperature
 - iii. Air circulation
 - iv. Moisture regulation
 - v. Microclimatic heating
 - c) Open hoophouse/Quonset structures: Modification of conditions possible
 - i. Temperature modification
 - ii. Air circulation
 - iii. Moisture regulation
 - iv. Initiation of hardening off process
 - d) Cold frames: Modification of environmental conditions
 - i. Temperature control: Advantages and disadvantages
 - ii. Air circulation
 - iii. Moisture delivery
 - iv. Initiation of hardening off process possible
 - e) Outdoor benches: Approximating in-ground conditions and hardening off process
 - i. Full exposure to sunlight, wind, day/night temperature flux

B. Propagation Media and Plant Propagation

1. Role of propagation media
 - a) Create idealized structure/texture
 - b) Supply nutrients
 - c) Provide drainage
 - d) Retain moisture
 - e) Facilitate aeration
 - f) Discourage pathogens
2. Philosophical basis for propagation media
 - a) Sustainable, renewable ingredients to reduce energy use
 - b) Live, biologically active mixes to assure disease-suppressive qualities
 - c) Texture, structure, nutrients, and cultural practices to foster healthy growth
3. Conventional approach to propagation media
 - a) Drainage, aeration, moisture paramount
 - b) Sterile ingredients
 - c) Fertility: Synthetic-fertility based
 - d) Efficiency, ease of handling, lower weight for shipping and handling
4. Propagation media/ingredients: Storage and handling
 - a) Ingredients: Protect from degradation and contamination by protecting from sun and rain
 - b) Propagation mixes: Similarly protected and made in small batches
 - c) Commonly used propagation ingredients (see appendix 7, Sample Soil Mix Recipes)
 - i. Peat moss/coir fiber
 - ii. Perlite
 - iii. Vermiculite
 - iv. Sand
 - v. Compost
 - vi. Soil
5. Supplemental fertility
 - a) Uses
 - i. To compensate for nutrient deficiencies
 - ii. To stimulate biological activity and nutrient liberation
 - iii. To alleviate plant stress
 - iv. As a growth accelerant
 - b) Potential concerns
 - i. Leachability of nutrients
 - ii. Input cost
 - iii. Additional labor, filtration, application tools
 - iv. Possibility of nitrogenous, pest-susceptible growth
 - v. Philosophic compromise: Over reliance on concentrated fertilizers
 - c) Organic sources of supplemental fertilizers for propagation (see Resources section for OMRI-certified supplemental fertilizers; see Fertilizers Solutions Chart in Unit 1.11, Reading and Interpreting Soil Test Reports)
 - i. Fish emulsions and soluble fish powders for N-P-K (~4N-2P-2K)
 - ii. Kelp extracts for micro nutrients and growth stimulants
 - iii. Worm castings tea (dilute N-P-K and disease suppression)

- iv. Compost tea (dilute N-P-K and disease suppression)
- v. Other supplemental liquid fertilizers accepted under OMRI/National Organic Program standards
- d) Modes of application
 - i. Dry ingredients are blended into mixes
 - ii. Soil-based application with irrigation, i.e. “fertigation”
 - iv. Foliar spray

C. Container Formats (see appendix 3, Examples of Propagation Containers)

1. Cell/plug trays
 - a) Advantages
 - b) Disadvantages
2. Traditional wooden flats
 - a) Advantages
 - b) Disadvantages

D. Pests and Pathogens in Propagation Facilities

1. Preventive measures
 - a) Sanitation of tools, facilities
 - b) Propagation media as sources of contamination or disease suppression
 - i. Biologically active, disease-suppressing media
 - ii. Sterile, soilless media
 - iii. Utilize heat/steam and solar pasteurization
 - c) Seed/plant stock as source of contamination
 - i. The use of disease-free seed/propagules
 - ii. Seed pretreatment
2. Good cultural practices
 - a) The use of pest/disease-resistant varieties
 - b) Growing crops at appropriate seasonal junctures
 - c) Managing environmental conditions to mitigate against pathogens and for optimal plant growth
 - i. Temperatures
 - ii. Moisture management
 - iii. Air circulation
 - iv. Fertility management
3. Management for the early detection and treatment of pest/disease problems
 - a) Identification of pests and pathogens (see Resources section)
 - b) Establish tolerance thresholds for active treatments
 - c) Monitor at regular frequency: Plant observations, sticky traps, etc.
 - d) Rogue, cull, or quarantine infected crops and/or
 - e) Use of certified organic chemical or biological controls (see Resources section)
4. Common greenhouse pests and pathogens and their management for your area include
 - a) Pests:
 - b) Pathogens:
5. Other resources
 - a) Consulting with local growers regarding pest management strategies

Detailed Lecture 2 Outline: Propagation Facilities, Media, and Container Formats

for students

A. Propagation Facilities

1. Advantages
 - a) Ability to control/modify environment
 - i. Temperature
 - ii. Air circulation
 - iii. Moisture delivery
 - b) Environmental control gives grower ability to:
 - i. Optimize growing conditions
 - ii. Extend parameters of growing season, early and late
 - iii. Produce vigorous/healthy transplants that can withstand pest pressure and variable weather conditions
 - iv. Avoid conditions wherein some seeds, especially large-seeded crops, are vulnerable to rotting in cold, wet soils
 - c) Transplants and efficiency
 - i. Efficient use of seed: Higher germination percentage under optimal conditions
 - ii. Efficient use of space and water: High plant density, concentration of resources
 - iii. Reduced growing time in ground: Early development in propagation site, thus allowing multi-cropping in same plot of ground. Increases likelihood that slow-maturing crops can complete life cycle in short-season areas.
2. Disadvantages
 - a) Added costs
 - i. Requires capital outlay for infrastructure construction and upkeep
 - ii. Requires capital outlay for containers and soil mix/ingredients
 - b) Labor
 - i. Additional labor especially early in season; significant time may be required to manage plants/facilities depending on diversity of crops and technology of system
 - ii. Sophisticated skills necessary to create/maintain idealized growing conditions
 - iii. Sowing and then transplanting requires an additional step (two steps if also pricking out seedlings)
 - c) Transplanting not practical or effective for all crops
 - d) Transplanting, in most cases, requires more total days of growth
 - e) Density of plants carries potential risk of crop loss/damage from pests/disease
 - f) Greater reliance on nonrenewable resources/materials
 - i. Greenhouse coverings: Plastics
 - ii. Containers: Plastics, styrofoam
 - iii. Soil media, mined resources: Peat, sand, perlite, vermiculite (see appendix 6, Propagation Media—Ingredients and Properties Imparted)
 - iv. Temperature regulation: Non-passive systems consume fossil fuels

3. Types of propagation facilities and how environmental control is achieved
- a) Enclosed (semi) automated greenhouses: Precise environmental control achievable
 - i. Characterized by ability to fully close growing environment, regulate temperatures/ air circulation through passive and active venting and air movement, heating/cooling by fans, furnaces, swamp cooler, etc.
 - ii. Microclimatic heating in root zone to optimize conditions via hot water pipes or electric cables on bench tops below containers
 - iii. Moisture regulation: Delivery by automated or manually controlled sprinkler systems
 - iv. Trapping solar radiation as secondary heating method
 - b) Passive solar greenhouse: Good environmental control is possible
 - i. Trapping solar radiation as primary means of warming
 - ii. Use of venting systems to affect cooling, drawing in cooler external air, exhausting warmer internal air
 - iii. Air circulation, exchange achieved by manually (typically) controlled venting design
 - iv. Moisture regulation/delivery totally under control of grower through hand delivery, manual, or automated delivery systems
 - v. Use of microclimatic heating also possible, practical with available power supply
 - c) Open hoophouse/Quonset hut structures: Give ability to partially modify existing environmental conditions
 - i. Modification of temperatures: Umbrella-like coverage creates slightly warmer day and night conditions
 - ii. Slight buffering against effects of wind, but no control over air circulation except by location of structure
 - iii. Grower still assumes full control over moisture regulation, delivery through same means as in greenhouses
 - iv. Exposure of plants to wind and greater day-night temperature fluctuation begins process of hardening off
 - d) Cold frames: Can be used like small-scale greenhouse and hoophouse facilities to modify environmental conditions
 - i. Ability to quickly heat internal air during daytime and to buffer against cold nighttime temperatures, but small air mass has limited capacity to protect and is prone to rapid temperature shifts
 - ii. Air circulation achieved through opening of frame, passive air exchange; danger of cold frame becoming too hot and humid if not vented in a timely manner
 - iii. Moisture delivery totally under grower control, usually by hand
 - iv. Through greater venting, thus more air flow, and day-night temperature fluctuation, grower can initiate hardening off process
 - e) Outdoor benches: Closely approximating in-ground conditions, completing hardening off process
 - i. Full exposure to sunlight, wind, and fluctuations in temperature stimulates the building of carbohydrate reserves and strengthening of cell walls

B. Propagation Media and Plant Propagation

1. Role of propagation media
 - a) To provide idealized environment, suitable texture/structure to provide support/anchorage and foster healthy seedling development
 - b) Media components to supply necessary nutrients
 - i. Compost
 - ii. Soil
 - iii. Organic matter amendments and fertilizers: e.g., blood meal (N), bone meal (P)
 - iv. Mineral amendments: e.g., lime (Ca), soft rock phosphate (P), greensand (K), etc.
 - c) Media must provide adequate physical properties for drainage to prevent development of fungal pathogens, rotting roots, accomplished through the use of:
 - i. Sand
 - ii. Perlite
 - iii. To a lesser extent, drainage also provided by compost, vermiculite, peat moss, leaf mold (partially decomposed leaf litter)
 - d) Media must also allow for moisture retention, accomplished through the use of:
 - i. Compost
 - ii. Peat moss/coir fiber
 - iii. Vermiculite
 - iv. Leaf mold
 - v. To a lesser extent, moisture retention also provided by soil, sand, perlite
 - e) Media must also facilitate aeration, allowing soil pore spaces to exchange O₂ and CO₂. This is accomplished through the addition of:
 - i. Perlite
 - ii. Sand
 - iii. Vermiculite
 - iv. Leaf mold
 - v. To a lesser extent by peat, coir fiber, and coarse composts
 - f) Media should be pathogen-free and with proper cultural practices not be conducive to pathogen development
2. Philosophical basis for propagation media
 - a) Emphasis on non-toxic, naturally occurring, renewable, non-extractive ingredients
 - b) Live, biologically active mixes, reliant principally on natural processes, diverse soil organisms to:
 - i. Release necessary nutrients
 - ii. Keep diseases in check
 - c) Texture, structure, nutrient supply combined with cultural practices are intended to foster healthy, uninterrupted growth
3. Conventional propagation media
 - a) Drainage, aeration, moisture retention still paramount but concern over energy required to produce mix is lower priority
 - b) Sterile ingredients are used to prevent pathogens
 - c) Fertility through liquid-soluble, granular, petrochemical-based sources
 - d) Efficiency, ease of handling and transport are prioritized through the use of lightweight ingredients such as peat, vermiculite

4. Media/ingredients storage and handling
 - a) Ingredients should be protected from degradation by sun, wind, rain, extreme temperatures, and stored away from potential pathogen sources in cool, well-aerated storage area
 - b) Mix media should be similarly protected and blended in small batches for near-term use. Long-term storage can lead to compaction, loss of structural properties, and diminished nutrient supply.
5. Supplemental fertility
 - a) Conditions when necessary
 - i. To compensate for poor quality, nutrient-deficient ingredients, especially immature or older, poorly stored compost
 - ii. To promote biological activity, nutrient release
 - iii. To alleviate stress, especially in cell-type containers when plants are past optimal transplant stage or showing signs of nutrient deficiency
 - iv. As growth accelerator—when trying to stimulate plant growth for a specific plant-out or sale date
 - b) Potential concerns
 - i. Possible leaching of nutrients, e.g., fish emulsion
 - ii. Input cost can be significant
 - iii. Additional labor for application, need for filtration, application tools
 - iv. Possibility of promoting highly nitrogenous, pest-susceptible growth in plants
 - v. Overreliance on highly soluble nutrient inputs
 - c) Organic sources of supplemental fertilizers for propagation (see resources section for OMRI-/NOP-certified supplemental fertilizers; see Fertilizers Solutions Chart in Unit 1.11, Reading and Interpreting Soil Test Reports)
 - i. Fish emulsions and soluble fish powders for N-P-K (~4N-2P-2K)
 - ii. Kelp extracts for micro nutrients and growth stimulants
 - iii. Worm castings tea (dilute N-P-K and disease suppression)
 - iv. Compost tea (dilute N-P-K and disease suppression)
 - v. Other supplemental liquid fertilizers accepted under OMRI/NOP standards
 - d) Modes of application
 - i. Blended into mixes at time of mix making, requires advance knowledge of need, useful with meals and powdered ingredients, typically slow acting
 - ii. Soil application, i.e. “fertigation”: Useful quick-fix approach to address nutrient deficiencies. Uses readily available, water-soluble nutrients, delivered with irrigation to root zone
 - iii. Foliar spray: Direct application to leaf stomata, another quick fix approach, with soluble nutrients

C. Container Formats (see appendix 3, Examples of Propagation Containers)

1. Cell/plug type trays: Provide grower with many options in size, shape of cells. Key is to match nature of container with appropriate media, size of desired transplant, and available propagation space.
 - a) Advantages to cell/plug formats
 - i. High plant density per square foot
 - ii. Limited consumption of soil media
 - iii. Individual units readily separable for transplanting
 - iv. Little/no root disturbance with proper root knit, thus little/no transplant shock
 - v. Roots “air pruned,” promoting early branching

- b) Disadvantages of cell/plug format
 - i. Limited soil volume equals limited nutrient supply, thus increasing possible need for supplemental fertility
 - ii. Limited soil volume equals limited root run, narrows window of opportunity for optimal transplant timing
 - iii. Limited soil volume increases necessary watering frequency
 - iv. Some plug trays don't provide adequate drainage
 - v. Potential for root spiraling in non-"speedling" style trays
 - vi. Trays constructed from nonrenewable resources, i.e., plastic/styrofoam
- 2. Traditional wooden propagation flats
 - a) Advantages
 - i. Format provides large root run and this longer window of opportunity can grow large, vigorous starts resistant to pest and disease pressure, and tolerant of weather variables
 - ii. Substantial nutrient supply per plant
 - iii. Less frequent watering needs
 - b) Disadvantages
 - i. Format requires large volume of soil media, and thus increased cost
 - ii. Lower plant density
 - iii. Flats are heavy, requiring more labor
 - iv. Greater potential for root disturbance, transplant shock

D. Pests and Pathogens in Propagation Facilities

1. Management program begins prior to propagation with preventive measures, identifying and eliminating possibility of contamination
 - a) The propagation facilities: Pots, flats, hand tools, hoses, benches can all harbor plant pathogens. Sanitation measures include cleaning or disinfecting materials and facilities.
 - b) Propagation media can be another source of contamination, especially for soil borne bacteria/fungi. The grower can:
 - i. Use biologically active, disease-suppressing media, or
 - ii. Sterile, soilless media, or
 - iii. Use heat/steam and solar pasteurization methods to sterilize media
 - c) Seed/plant stock can also be a source of contamination. The grower can protect against this potential by:
 - i. Using seed/propagule material that is certified to be disease free
 - ii. Using seed pretreatment techniques such as hot water baths
 - d) Exclusion of pests from growing environment
 - i. Screening at all points of entry
 - ii. Floating row covers over cell trays
2. Good cultural practices are a critical component in the management/prevention of pest/disease challenges
 - a) Select pest- and disease-resistant varieties and avoid crops vulnerable to known potential problems. Check with local growers and extension agents.
 - b) Grow crops at appropriate seasonal junctures to facilitate healthy, vigorous, pest- and disease-resistant growth

- c) Manage environmental conditions to mitigate against the presence of pests/disease and promote vigorous, uninterrupted growth. This includes control of:
 - i. Temperatures, especially in the prevention of damping off organisms, which thrive in the 68°F to 86°F range and constantly moist conditions. While the temperate range conducive to crop growth parallels that which promotes damping off organisms, their presence can be reduced or eliminated by managing for appropriate moisture fluctuations in growing media.
 - ii. Moisture management: The timing and quantity of moisture delivered are also important. Excess soil moisture and poor drainage can reduce plant vigor and increase susceptibility. Wet-to-dry swings in soil moisture can be effective in preventing conditions that promote damping off and other fungal organisms.
 - iii. Air circulation, or oxygen exchange within the greenhouse, is also critical in the prevention of pathogen buildup, and aids in temperature flux and soil drying
 - iv. Fertility management: In concert with other cultural practices, adequate but not excessive soil fertility promotes healthy, uninterrupted growth (see appendix 7, Sample Soil Mix Recipes)
- 3. Management also includes monitoring and early detection of pest/disease problems to minimize crop loss and minimize need for intervention
 - a) Identification of pest/disease (see Flint 1998; Dreistadt 2001; www.ipm.ucdavis.edu)
 - b) Establish tolerance thresholds to initiate control actions
 - c) Monitor at regular frequency: Plant observations, sticky traps, etc.
 - d) Roguing (culling), or quarantining infected crops
 - e) Use of organically acceptable chemical controls, or biological control agents (see Flint 1998; Dreistadt 2001; www.ipm.ucdavis.edu)
- 4. Common greenhouse pests and pathogens and their management (see Flint 1998)
 - a) Pests
 - i. Aphids
 - ii. Scales
 - iii. Mealybugs
 - iv. Whiteflies
 - v. Cabbage loopers
 - vi. Flea beetles
 - vii. Mites
 - b) Pathogens
 - i. Damping off fungi
 - ii. Powdery mildews
 - iii. Downy mildews
 - iv. Root rot: Rhizoctonia, Pythium
 - v. Crown rot: Erwinia
 - vi. Rusts
- 5. Additional resources
 - a) The use of local growers as resources: The above-listed pests and pathogens can typically be found throughout the country. Speaking with local growers, cooperative extension agents, and IPM practitioners is an essential step in researching what problems to anticipate, their severity, and the probable times of year to be especially vigilant.

Demonstration 1: Greenhouse Management

for the instructor

OVERVIEW

This demonstration provides students with an understanding of the working components of the greenhouse facility and the tools available to manage environmental conditions that best meet the needs of pre-emergent and seedling crops in the facility. Students should become familiar with the fundamental skills and concepts to create ideal growing conditions, such as temperature and air circulation management.

PREPARATION AND MATERIALS

- A working greenhouse structure where the essential management tools and techniques can be discussed and demonstrated
- Thermometer and appendix 11, Greenhouse Records Sheet, to show current conditions and records of recent temperature fluctuations
- Thermometers positioned in different microclimatic zones (if applicable) to show how differences can be used to meet different plant needs under a single management regimen

PREPARATION TIME

1 hour

DEMONSTRATION TIME

1 hour

DEMONSTRATION OUTLINE

A. Managing Greenhouses

1. Discuss and demonstrate orientation of greenhouse (i.e., solar aspect)
2. Discuss and demonstrate methods for air circulation via venting, fans, etc.
3. Discuss and demonstrate temperature management
 - a) Ideal temperature ranges (see appendix 2)
 - b) How heat is retained
 - c) The use of thermal mass in heat retention
 - d) Techniques for evaporative cooling
 - e) The role of venting in maintaining ideal temperature, humidity, and gas exchange
 - f) Active heating systems
4. Use of microclimates within greenhouse
5. Discuss and demonstrate record keeping in the greenhouse (see appendix 11, Greenhouse Records Sheet)
 - a) Date
 - b) Previous high/low
 - c) Current temperature
 - d) Weather description
 - e) Description of environmental conditions in greenhouse

Demonstration 2: Propagation Media

for the instructor

OVERVIEW

Students will examine both unblended propagation ingredients and the completed propagation media. By looking at the individual ingredients, finished propagation media, and typical garden soils in containers, students will see the components of propagation media that are critical to creating proper drainage, aeration, and moisture retention. The instructor should also emphasize the importance of proper moisture in propagation media so that root-to-soil and/or seed-to-soil contact can be achieved with only minimal additional water inputs. Instructors should be certain to discuss the importance of proper storage and handling of media to maintain fertility and protect against contamination by pathogens.

PREPARATION AND MATERIALS

1. Have both wet and dry samples of several possible raw ingredients that are used in propagation media: compost, soil, sand, perlite, vermiculite, composted wood chips, grape seed pumice, peat moss, and coir fiber, etc.
2. Have wet and dry samples of the media commonly used in your operation and perhaps others such as the Cornell Peat Lite Mix and the UC Potting Mix (see Resources section) and/or commercial propagation media for comparison.
3. Assemble necessary tools (flat head shovels, wheelbarrows) and hoses to supply moisture.
4. Assemble ingredients to make the desired mix of ingredients

PREPARATION TIME

1.5 hours

DEMONSTRATION TIME

1.5 hours

DEMONSTRATION OUTLINE

A. Propagation Media

1. Review desirable characteristics of propagation media
2. Review individual media constituents and properties imparted by each
 - a) Show ingredients that provide nutrients (N, P, K, and micronutrients)
 - b) Show ingredients that promote drainage and aeration
 - c) Show ingredients that serve to retain moisture
3. Demonstrate the techniques of blending materials to create homogenized media
4. Assess and adjust media for appropriate moisture
5. Discuss use and proper storage techniques for propagation media

Demonstration 3: Sowing Seed

for the instructor

OVERVIEW

In this demonstration students should observe and participate in sowing a variety of different seed types and sizes in both cell trays and wooden flats. Students will review the advantages and disadvantages of each format and why certain crops may be better suited to a particular method. In this session, a discussion and look at various seed sizes will illustrate the importance of sowing seeds to appropriate depths to ensure a high percentage of germination and seedling survival.

PREPARATION AND MATERIALS

1. Assemble a selection of different cell/plug trays.
2. Assemble wooden flats suitable for seed sowing.
3. Bring both large (sunflowers, squash, etc.) and small seeds (lettuce, larkspur, snapdragon, etc.) to illustrate the range of seed sizes.
4. Bring any mechanical seeding devices such as sliding plate seeders and seeds appropriate to their use.

PREPARATION TIME

1 hour

DEMONSTRATION TIME

1 hour

DEMONSTRATION OUTLINE

A. Seed Sowing Techniques

1. Demonstrate container-filling techniques
2. Discuss the advantages and disadvantages of each container format (see appendix 3)
3. Demonstrate sowing and coverage techniques (see appendix 1)
 - a) Discuss and demonstrate techniques for broadcasting and drilling seed into flats, including proper depth
 - b) Discuss the significance of seed density as it relates to potential future competition and timing of pricking out
 - c) Discuss and demonstrate sowing by hand into cell type trays
 - d) Discuss and demonstrate sowing into cell trays with a sliding plate seeder or other mechanisms
4. Discuss labeling and record keeping and their importance in maintaining variety distinctions, trouble shooting, and future crop planning (see appendix 10)
5. Discuss and demonstrate watering-in techniques
6. Discuss and demonstrate optimal min/max germination temperatures (see appendix 2)
7. Discuss days to germination at varying temperatures (see appendix 4)
8. Discuss and demonstrate optimal post-germination growing temperatures for seedlings (see appendix 5)

Demonstration 4: Transplanting or “Pricking Out” *for the instructor*

OVERVIEW

This demonstration illustrates the technique of transplanting immature seedlings from a high-density flat format to a lower-density format. The importance of doing this work under appropriate environmental conditions (low light levels, low temperatures, high relative humidity, and still air/low wind velocity) cannot be overemphasized. Students will have the chance to look at plant development and its relevance to successful transplanting or “pricking out” in the greenhouse setting. Be sure to emphasize the significance of seedling density and proper timing of pricking out to prevent undue competition for resources and to prevent diseases.

PREPARATION AND MATERIALS

1. Have plants available for visual inspection that only show taproot development.
2. Gather plants that have initiated a branched root system suitable for pricking out.
3. Have plants showing signs of overdevelopment that would make pricking out more difficult.
4. Have undersown (very low-density) flats to illustrate inefficient use of space as well as the wider window of opportunity possible when young plants are not competing for resources.
5. Have oversown flats illustrating the effects of competition and the imperative of moving swiftly to prevent disease and alleviate the effects of nutrient stress.
6. Have flats sown at appropriate density to demonstrate best use of space and proper timing for movement.
7. Have plants of basal rosette nature (e.g., statice, *Limonium sinuatum*) and upright nature (e.g., snapdragons, *Antirrhinum majus*) to discuss and demonstrate appropriate planting depth relative to seedling architecture and physiological adaptations such as adventitious rooting.

PREPARATION TIME

1 hour

DEMONSTRATION TIME

1.5 hours

DEMONSTRATION OUTLINE

A. Transplanting and Pricking Out Techniques (see appendix 8)

1. Review/discuss environmental conditions appropriate to plant handling
2. Discuss and demonstrate stages of plant development appropriate for pricking out
3. Discuss and demonstrate plant root systems appropriate for pricking out
4. Discuss and demonstrate the significance of seedling density relative to timing of pricking out
5. Discuss and demonstrate proper/gentle handling techniques when dealing with young/easily injured seedlings
6. Discuss and demonstrate techniques for watering-in transplants
7. Discuss labeling and record keeping and their importance in maintaining variety distinction, trouble shooting, and future crop planning (see appendix 10)
8. Discuss considerations for post-transplant care

Demonstration 5: Greenhouse Irrigation

for the instructor

OVERVIEW

In this demonstration, students will learn about the various tools and techniques used to deliver water to pre-emergent seeds and seedlings in a given propagation facility. Emphasis should be placed on creating optimal soil moisture conditions to facilitate healthy plant growth through proper irrigation frequencies and volumes of water applied. You should also discuss the advantages and disadvantages of the systems and tools used.

PREPARATION AND MATERIALS

- All irrigation equipment commonly used in the propagation facility (e.g., hoses, watering cans, fixed spray nozzles, irrigation timers and solenoid control valves, mist systems, etc.)
- Recently sown seeds in flat and cell tray format
- Seedlings in flat and cell tray format

PREPARATION TIME

1 hour

DEMONSTRATION TIME

1 hour

DEMONSTRATION OUTLINE

A. Irrigating Seeds and Seedlings

1. Discuss and demonstrate irrigation techniques prior to seedling emergence with attention to the differences in wet-to-dry swing for large- and small-seeded crops
2. Discuss and demonstrate irrigation techniques used for post-seedling emergence and early seedling development
3. Discuss the typical changes in frequency and volume of water delivered during seedling development (i.e., from pre-germination—frequent, shallow applications—to lower frequency, greater volume of water supplied as seedlings mature)
4. Discuss and demonstrate any necessary adjustments needed based on germination, disease or pest problems, and/or plant growth observations
5. Emphasize the importance of paying extra attention to corners and edges of greenhouse; these are often overlooked

Demonstration 6: Seedling Development and the “Hardening Off” Process

for the instructor

OVERVIEW

This demonstration shows students how to prepare seedlings for field transplanting.

PREPARATION AND MATERIALS

- Seedlings at varying stages of maturity

PREPARATION TIME

0.5 hour

DEMONSTRATION TIME

0.5 hour

DEMONSTRATION OUTLINE

A. The Hardening Off Process

1. Define the hardening off process and its role in seedling maturation and survival
2. Discuss characteristics of seedling maturity (see appendix 9)
3. Discuss regional importance and influence on duration of hardening off process. Greater temperature differences between greenhouse and field conditions will require a longer hardening off period.
4. Discuss and demonstrate the various propagation structures and techniques used in the hardening-off progression
 - a) Highly controlled environment of greenhouse settings
 - b) Partially moderated conditions: Hoophouses
 - c) Outdoor benches approximating field conditions
5. Provide examples of seedlings prepared for transplanting

- 6) What pieces of information are commonly documented in the propagation process and why?

- 7) What is the “hardening off” process?

- 8) List two characteristics of cell-tray-grown seedlings at transplanting maturity

- 9) List two necessary steps for preparing seedlings before transplanting them to the field or garden.

- 10) List the environmental conditions most favorable for successful bare-root transplanting/ pricking out seedlings grown in a flat format.

- 11) Describe four preventive measures and two active measures used to control fungal plant pathogens in greenhouse facilities.

Assessment Questions Key

- 1) List two pre-conditions that must be met for seed germination and four environmental conditions that must be achieved for optimal seed germination.

Pre-conditions:

- *Viable seed*
- *Dormancy factor released*

Necessary environmental conditions for seed germination and role of each:

- *Optimal temperature range: To increase the rate of respiration*
- *Optimal moisture range: To soften seed coat and increase the rate of respiration*
- *Aeration: To provide adequate air circulation for supplying oxygen used in respiration and remove carbon dioxide produced during respiration*
- *Light: Though not needed for germination of all seeds, light stimulates increased respiration in some plants*

- 2) What is the optimal average daytime temperature range that should be maintained in the greenhouse for the germination and early growth of most annual vegetables and cut flowers? What would be the minimum nighttime temperature?

- *Optimal average temperature range is between 65-85°F. (The average optimal germination temperature for most vegetables and cut flowers is 82°F. Please see appendix 2 for specific minimum, maximum, and optimal germination temperatures.)*
- *Minimum nighttime temperature should not dip below 55°F*

- 3) List four advantages of the use of greenhouse-raised transplants over direct seeding of crop plants. Describe two disadvantages.

Advantages of transplants:

- *Season extension*
- *Ability to manage environmental conditions: Temperature, moisture, air circulation and growing media*
- *Crop selection*
- *Ability to intensively manage large numbers of plants in a small area*
- *Efficient use of seed, water and space*

Disadvantages of transplants:

- *Additional infrastructure costs*
- *Additional skill and labor required*
- *Not all crops grow or transplant well from containers*
- *Additional non-renewable resource use*
- *Often results in more total days of growth*

- 4) Why is the careful selection of crop varieties important?

- *To help assure disease resistance*
- *To help assure good crop performance in different climates or micro-climates*
- *To help assure other crop qualities such as storage, visual aesthetics, flavor, etc.*

- 5) What are four important qualities of a propagation mix? List two propagation mix constituents that may be used to assure each of the previously listed qualities.

- *Drainage. Constituents that impart this quality: Perlite, sand, soil, leaf mould, gravels and lava rock, and to a lesser extent, vermiculite, compost, peat moss, and coir fiber*

- *Aeration. Constituents that impart this quality: Perlite, sand, soil, leaf mould, gravels and lava rock, and to a lesser extent, vermiculite compost, peat moss and coir fiber*
- *Density. Constituents that impart this quality: Sand, soil, gravel, compost, and leaf mould*
- *Nutrient availability. Constituents that impart this quality: Compost, soil, mineral and organic matter amendments, and leaf mould*
- *Water-holding capacity. Constituents that impart this quality: Compost, peat moss and coir fiber, vermiculite*

6) What pieces of information are commonly documented in the propagation process and why?

- *Genus and species of crop*
- *Variety of crop*
- *Date sown*
- *Date pricked out (if applicable)*
- *Seed company name*
- *Seed lot (year seed was produced for)*

Why: The above would provide adequate information for future trouble shooting and the selection of crops during variety trials

7) What is the "hardening off" process?

The gradual exposure and acclimation of greenhouse-raised transplants to the environmental conditions of the field.

8) List two characteristics of cell-tray-grown seedlings at transplanting maturity.

- *Second set of true leaves initiated*
- *Root knit*

9) List two necessary steps for preparing seedlings before transplanting them to the field or garden.

- *Pre-moistened to 75% field capacity*
- *Hardened-off for 3–21 days*

10) List the environmental conditions most favorable for the successful bare-root transplanting/ pricking out seedlings grown in a flat format.

- *Low light levels*
- *Low temperatures*
- *Low wind velocity*

11) Describe four preventive measures and two active measures used to control fungal plant pathogens in greenhouse facilities.

Preventive measures:

- *Proper sanitation of propagation media, facilities, and containers*
- *The selection and use of disease-resistant varieties*
- *The selection and use of climate-appropriate varieties*
- *The use of disease-free seed stock*
- *Management of environmental conditions of greenhouse (air circulation, temperature, light) and propagation media (moisture, aeration, nutrients) within the optimal range. Good cultural practices.*
- *Monitoring*

Active measures:

- *Roguing affected crops*
- *Biological control*
- *The use of acceptable chemical controls*

Resources

PRINT RESOURCES

Bunt, A. C. 1988. *Media and Mixes for Container Grown Plants*. Boston, MA: Unwin Hyman.

Extensive information on the creation of container mixes and managing fertility, principally by conventional means.

Deno, Norman. 1994. *Seed Germination Theory and Practices*. Self published, State College, PA.

Important reference on principles of seed germination and the utilization of specific techniques for a wide array of cultivated crops.

Dreistadt, Steve, and Mary Louise Flint. 2001. *Integrated Pest Management for Floriculture and Nurseries*. Publication 3402. Oakland, CA: University of California Division of Agriculture and Natural Resources.

Outstanding new resource for developing a pest management program.

Flint, Mary Louise. 1998. *Pests of the Garden and Small Farm and Garden: A Grower's Guide to Using Less Pesticide, Second Edition*. Publication 3332. Oakland, CA: University of California Division of Agriculture and Natural Resources.

Excellent tool for the identification of common greenhouse pests and pathogens.

Flint, Mary Louise, and Steve Dreistadt. 1998. *Natural Enemies Handbook: The Illustrated Guide to Biological Pest Control*. Publication 3386. Oakland, CA: University of California Division of Agriculture and Natural Resources.

A valuable resource for biological control of pests and pathogens.

Hanan, Joe. 1998. *Greenhouses: Advanced Technology for Protected Horticulture*. Boston, MA: CRC Press.

Exhaustive reference on all aspects of greenhouse design and management, written principally from a conventional perspective, but with much valuable information for the organic grower.

Hartmann, Hudson, Dale Kester, Fred Davies, Jr. and Robert Geneve. 1997. *Plant Propagation: Principles and Practices, Sixth Edition*. Upper Saddle River, NJ: Prentice Hall.

The standard reference tool for propagators, covering all aspects of sexual and asexual propagation, principally from a large-scale, conventional focus.

Johnston, Robert Jr. 1983. *Growing Garden Seeds*. Albion, ME: Johnny's Selected Seeds.

Brief but valuable reference on seed viability and seed production strategies.

Jozwik, Francis. 1992. *The Greenhouse and Nursery Handbook*. Mills, WY: Andmar Press.

Good general information for small- to medium-scale growers.

Maynard, Donald and George Hochmuth. 1997. *Knott's Handbook for Vegetable Growers*. New York: John Wiley & Sons.

The standard reference for field -scale vegetable production, but also provides many valuable charts on seed viability, germination temperatures, days to germination, etc.

Milne, Lorus and Margery. 1980. *National Audubon Society Field Guide to North American Insects and Spiders*. New York: Alfred A. Knopf.

Great visual reference for identifying both beneficial and pest species.

Olkowski, William, Sheila Daar, and Helga Olkowski. 1991. *Common Sense Pest Control*. Newtown CT: Taunton Press.

Excellent reference for non-toxic pest control strategies geared both for homeowners and production-oriented growers.

Styer, Roger, and David Koranski. 1997. *Plug and Transplant Production*. Batavia, IL: Ball Publishing.

Excellent discussion on soils and containers and detailed information on managing environmental conditions for vegetable and cut flower transplants.

Thompson, Peter. 1992. *Creative Propagation*. Portland, OR: Timber Press.

Very user-friendly guide to growing plants from seed, cuttings, and divisions.

Walls, Ian. 1996. *The Complete Book of the Greenhouse*. London: Ward Lock.

Geared toward small-scale and backyard growers, this book provides good information on greenhouse design and management tools.

Yamaguchi, Mas. 1983. *World Vegetables*. New York: Van Nostrand Reinhold.

Invaluable resource on the history and origins of major world vegetable crops and their cultural requirements.

WEB RESOURCES

Appropriate Technology Transfer for Rural Areas

www.attra.org

ATTRA provides excellent information on soil mixes for containers, transplant production, amendments, supplemental fertilizers, compost tea and much more.

California Agriculture Teachers Association (CATA) Sustainable Agriculture Curriculum and PowerPoint Resources

www.ccagcans.com/cansdefault.html
(see "Course Curriculum")

The CATA Sustainable Agriculture Curriculum and PowerPoint site contains 5 courses (including course descriptions, outlines, and resource listings) and over 40 PowerPoint titles. Developed by leading agricultural professionals, these resources address various aspects of sustainable food systems and organic agricultural production practices.

Exploring Sustainability in Agriculture: An Online Sustainable Agriculture Instructional Resource, Center for Agroecology and Sustainable Food Systems

zzyx.ucsc.edu/casfs/instruction/esa/index.html

This online resource from the Center for Agroecology and Sustainable Food Systems includes a catalogue description and outline for a comprehensive course on sustainable agriculture, appropriate for the community college, state college, or university level. The outline and annotated resources address topics in social and environmental sciences; plant, soil,

crop, and animal sciences; pest management; natural resource management; the adoption of sustainable agriculture; and the growth and development of sustainable agriculture and the organic food industry.

Integrated Pest Management, UC Davis

www.ipm.ucdavis.edu

Excellent resource for insect identification and non-chemical control strategies, as well as links to other sites concerned with pests and pathogens.

Soil Foodweb

www.soilfoodweb.com

Initiated by Dr. Elaine Ingham, Soil Foodweb Inc. is a clearinghouse for information and research summaries on soil ecosystem process and a product, services and resource for how to grow crop plants without the use of pesticides or inorganic fertilizers. Includes how-to manuals on the production of compost teas.

SUPPLIERS

Johnny's Selected Seeds

(207) 437-4395, www.johnnyseeds.com

Good selection of vegetable and flower seed, with excellent cultural information.

MC Development Sales

(800) 511-6151, www.developmentsales.com

Large distributor of greenhouse and propagation supplies.

Peaceful Valley Farm Supply

PO Box 2209, Grass Valley, CA

(888) 784-1722, www.groworganic.com

Suppliers of Plantel and Speedling trays, and fertility amendments.

Speedling

PO Box 7238, Sun City, FL 33586

(800) 426-4400

Source of Speedling trays.

Stuppy Greenhouse Manufacturing

1212 Clay Road, North Kansas City, MO 64116

(800) 733-5025, www.stuppy.com

Source of greenhouses and greenhouse supplies.

Glossary

Aeration

To add oxygen

Annual

A plant that completes its life cycle (germination through death) in one year or growing season, essentially non-woody

Asexual propagation

Propagation by vegetative means, rather than by seed. Not sexual, i.e., not involving the fusion of male and female sex cells.

Biennial

A plant completing its life cycle (germination through death) in two years or growing seasons (generally flowering only in the second) and non-woody (at least above ground), often with a rosette the first growing season)

Cell Tray

Multi-cell propagation container, also known as “plug tray”

Cotyledon

Seed-leaf; a modified leaf present in the seed, often functioning for food storage. Persistent in some annuals and helpful in their identification.

Cross pollination

The transfer of pollen from one plant to another

Dicot

Flowering plant having two cotyledons (e.g., poppy, cactus, rose, sunflower)

Damping Off

A fungal pathogen whose populations are encouraged by consistently high moisture levels in the propagation media and high humidity. Negatively affect developing seedlings, often leading to lodging. Presence indicated by brown ring of compromised tissue around stem of plant. Often leads to losses.

Embryo

An immature plant within a seed

Endosperm

The starch- and oil-containing tissue of many seeds used by the seedling in the initial stages of development prior to the beginning of photosynthesis

F-1 Hybrid

A plant resulting from a cross between two genetically distinct individuals, which allows for the combination and expression of desirable traits in the F-1 generation

Fertigation

Fertilizer delivered through irrigation equipment

Fertilization

The use of concentrated forms of nutrients (e.g., fish emulsion to deliver soluble sources of nitrogen)

Hardening Off

The process of gradually exposing greenhouse-raised transplants to field conditions resulting in the development of more resistant and resilient seedlings

Imbibition

The process of water absorption by a dry substance or structure, causing it to swell

Monocot

Flowering plant having one cotyledon (e.g., lily, orchid, grass, cat-tail, palm)

Open pollination

The placing of pollen on a stigma or stigmatic surface by natural means, e.g., insect, wind, etc.

Perennial

A plant with a life cycle of more than two years

Photoperiodism

The response of a plant to the relative duration of day and night, especially in regard to flowering

Plumule

The young shoot as it emerges from the seed on germination, usually after the appearance of the radicle

Pricking Out

A traditional French-intensive method of raising seedlings in wooden flats, where seedlings are transplanted from a sowing flat at high density to a second propagation flat at lower density

Propagation Media

The growing media in which seeds are germinated and seedlings are grown

Radicle

The young root as it emerges from the seed, normally the first organ to appear on germination

Roguing

The selective removal of seedlings affected by pests or pathogens

Scarification

Scratching or etching a thick seed coat to improve water uptake

Sexual Propagation

The intentional reproduction of a new generation of plants by the germination and growth of seeds that were created in the previous generation through the fertilization of a plant ovary via the union of male and female sex cells. Results in a genetically unique plant generation.

Stratification

The exposure of ungerminated seeds to either warm or cold temperature extremes to release chemical dormancy factors

Transpiration

The loss of water vapor from a plant, mostly from the stomata of leaves

Viability

Capability of germination

Appendix 1: Seed Viability Chart

SEED TYPE	WITH NO SPECIAL STORAGE CONDITIONS (YEARS)	IN CONSISTENTLY COOL/DRY CONDITIONS (YEARS)
Beans, all	2–3	4–6
Beets	2	3–4
Broccoli	2	4–5
Brussels Sprouts	2	4–5
Burdock	2	4–5
Cabbage, regular	2	4–5
Cabbage, Chinese	3	5–8
Cantaloupe	3–4	6–10
Carrot	1–2	3–5
Cauliflower	2	4–5
Celery	1–2	3–5
Collard	2	4–5
Corn, all	1–2	4–6
Cucumber	3	5–7
Eggplant	1–2	3–5
Endive/Escarole	2	3–4
Kale	2	4–5
Kohlrabi	2	4–5
Leeks	up to 1	2–4
Lettuce	1–2	3–4
Mustard	2–3	5–8
Onion	up to 1	2–4
Parsley	1–2	3–5
Parsnip	up to 1	1–3
Peas	1–2	4–6
Pepper	1–2	3–5
Potato (true seed)	2–3	5–7
Pumpkin	1–2	3–5
Radish	2	3–5
Rutabaga	2	3–5
Salsify	2	3–4
Scorzonera	2	3–4
Spinach	1–2	3–4
Squash	1–2	3–5
Strawberry	2–3	3–6
Sunflower	2	4–6
Swiss Chard	2	3–4
Tomato	2–3	4–7
Turnip	2–3	5–8
Watermelon	2–3	4–6

Appendix 2: Soil Temperature Conditions for Vegetable Seed Germination

VEGETABLE	MINIMUM (°F)	OPTIMUM RANGE (°F)	OPTIMUM (°F)	MAXIMUM(°F)
Asparagus	50	60 – 85	75	95
Bean	60	60 – 85	80	95
Bean, lima	60	65 – 85	85	85
Beet	40	50 – 85	85	95
Cabbage	40	45 – 95	85	100
Carrot	40	45 – 85	80	95
Cauliflower	40	45 – 85	80	100
Celery	40	60 – 70	70 ¹	85 ¹
Chard, Swiss	40	50 – 85	85	95
Corn	50	60 – 95	95	105
Cucumber	60	60 – 95	95	105
Eggplant	60	75 – 90	85	95
Lettuce	35	40 – 80	75	85
Muskmelon	60	75 – 95	90	100
Okra	60	70 – 95	95	105
Onion	35	50 – 95	75	95
Parsley	40	50 – 85	75	90
Parsnip	35	50 – 70	65	85
Pea	40	40 – 75	75	85
Pepper	60	65 – 95	85	95
Pumpkin	60	70 – 90	90	100
Radish	40	45 – 90	85	95
Spinach	35	45 – 75	70	85
Squash	60	70 – 95	95	100
Tomato	50	60 – 85	85	95
Turnip	40	60 – 105	85	105
Watermelon	60	70 – 95	95	105

¹Daily fluctuation to 60° F or lower at night is essential.

Compiled by J.F. Harrington, Dept. of Vegetable Crops, University of California, Davis.

Source: *Knott's Handbook for Vegetable Growers*, by Donald Maynard and George Hochmuth, Wiley & Sons, Inc., 1997. Used by permission of Wiley & Sons, Inc.

Appendix 3: Examples of Propagation Containers

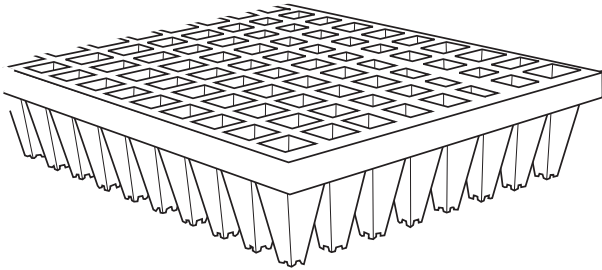

Cell Tray or Plug Tray

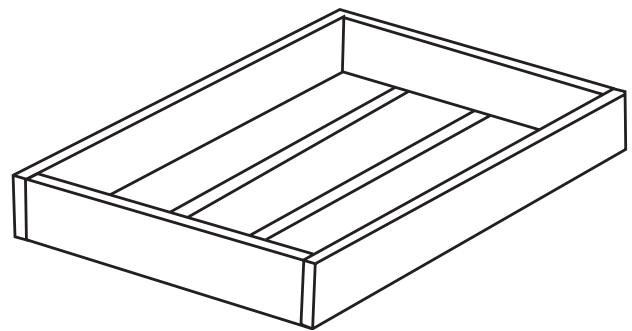

Wooden Flat

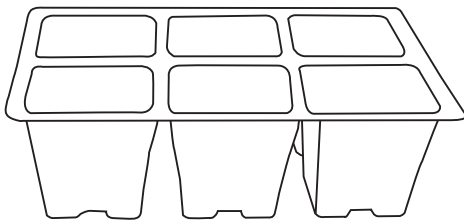

Six-Pack

illustrations by Cathy Genetti Reinhard; not to scale

Appendix 4: Days Required for Seedling Emergence at Various Soil Temperatures from Seed Planted 1/2 inch Deep

VEGETABLE	32°	41°	50°	59°	68°	77°	86°	95°	104°
Asparagus	NG	NG	53	24	15	10	12	20	28
Bean, lima	—	—	NG	31	18	7	7	NG	—
Bean snap	NG	NG	NG	16	11	8	6	6	NG
Beet	—	42	17	10	6	5	5	5	—
Cabbage	—	—	15	9	6	5	4	—	—
Carrot	NG	51	17	10	7	6	6	9	NG
Cauliflower	—	—	20	10	6	5	5	—	—
Celery	NG	41	16	12	7	NG	NG	NG	—
Corn, sweet	NG	NG	22	12	7	4	4	3	NG
Cucumber	NG	NG	NG	13	6	4	3	3	—
Eggplant	—	—	—	—	13	8	5	—	—
Lettuce	49	15	7	4	3	2	3	NG	NG
Muskmelon	—	—	—	—	8	4	3	—	—
Okra	NG	NG	NG	27	17	13	7	6	7
Onion	136	31	13	7	5	4	4	13	NG
Parsley	—	—	29	17	14	13	12	—	—
Parsnip	172	57	27	19	14	15	32	NG	NG
Pea	—	36	14	9	8	6	6	—	—
Pepper	NG	NG	NG	25	13	8	8	9	NG
Radish	NG	29	11	6	4	4	3	—	—
Spinach	63	23	12	7	6	5	6	NG	NG
Tomato	NG	NG	43	14	8	6	6	9	NG
Turnip	NG	NG	5	3	2	1	1	1	3
Watermelon	—	NG	—	—	12	5	4	3	—

NG = No germination, — = not tested

Adapted from J.F. Harrington and P.A. Minges, Vegetable Seed Germination, California Agricultural Extension Mimeo Leaflet (1954).

Source: *Knott's Handbook for Vegetable Growers*, 1997, John Wiley & Sons, Inc. Used by permission of John Wiley & Sons, Inc.

Appendix 5: Approximate Monthly Temperatures for Best Growth and Quality of Vegetable Crops

Some crops can be planted as temperatures approach the proper range. Cool season crops grown in the spring must have time to mature before warm weather. Fall crops can be started in hot weather to ensure a sufficient period of cool temperature to reach maturity. Within a crop, varieties may differ in temperature requirements; hence this listing provides general rather than specific guidelines.

OPTIMUM °F	MINIMUM °F	MAXIMUM °F	VEGETABLE
55°–75°	45°	85°	Chicory, chive, garlic, leek, onion, salsify, scolymus, scorzoneria, shallot
60°–65°	40°	75°	Beet, broad bean, broccoli, Brussels sprouts, cabbage, chard, collards, horseradish, kale, kohlrabi, parsnip, radish, rutabaga, sorrel, spinach, turnip
60°–65°	45°	75°	Artichoke, cardoon, carrot, cauliflower, celeriac, celery, Chinese cabbage, endive, Florence fennel, lettuce, mustard, parsley, pea, potato
60°–70°	50°	80°	Lima bean, snap bean
60°–75°	50°	95°	Sweet corn, Southern pea, New Zealand spinach
65°–75°	50°	90°	Chayote, pumpkin, squash
65°–75°	60°	90°	Cucumber, muskmelon
70°–75°	65°	80°	Sweet pepper, tomato
70°–85°	65°	95°	Eggplant, hot pepper, martynia, okra, roselle, sweet potato, watermelon

Source: *Knott's Handbook for Vegetable Growers*, by Donald Maynard and George Hochmuth, Wiley & Sons, Inc., 1997. Used by permission of John Wiley & Sons, Inc.

Appendix 6: Propagation Media — Ingredients and Properties Imparted

INGREDIENT	FUNCTION/QUALITIES IMPARTED	SOURCE	COMMENTS/SUSTAINABILITY COSTS
Peat Moss	Fungistatic/acidic, H ₂ O-holding capacity 10 times dry wt.		\$\$\$, pH 3.5-5.0 Non-renewable
Perlite 5–8 lbs/cu ft	H ₂ O holding capacity 3–4 times wt., aeration, drainage	Mined silica, volcanic origin	\$\$\$, no CEC ¹ , no nutrients
Vermiculite 6–10 lbs/cu ft	Drainage, High CEC, H ₂ O-holding capacity 6–8 times wt., has Mg/K	Mica from MT & NC	\$\$\$, Heated @2000°F to expand water-holding capacity
Compost	Moisture retention, drainage, nutrients, pathogen suppression	Produce	Requires labor to produce, weed seed
Soil	Minerals, minor NPK, bulk density	On-site	Free, weed seed
Sand	Drainage, aeration,	Quarried/Sharp	\$, 0.05-2.0mm diameter, no CEC or nutrients
Leaf Mold (decomposed leaf litter)	Serves as peat substitute, acidic/fungistatic, drainage, H ₂ O-holding	On-site	Free, labor to harvest
Coir Fiber	H ₂ O-holding, drainage	From Sri Lanka, Madagascar, coconut byproduct	\$\$, hard to handle/break up, non fungistatic
Grape Seed Pomace	Drainage, aeration	Winery byproduct	Time/labor, perlite substitute for mixes, could have high potas- sium

¹CEC=Cation Exchange Capacity (see Unit 2.2, Soil Chemistry and Fertility)

\$\$\$ = expensive input

\$\$ = moderately expensive input

\$ = low-cost input

Appendix 7: Sample Soil Mix Recipes

FLAT/SOWING MIX

3 parts compost (sifted .5 inch screen)
2 parts soil
1 part sand
2 parts coir fiber (premoistened) or 1 part coir fiber
+ 1 part leaf mold (sifted .5 inch screen)

GARDEN SPEEDLING MIX

2-1/2 compost (sifted .5 inch screen)
1 soil
2 coir fiber (premoistened) or 1 coir fiber + 1 leaf
mold (sifted .5 inch screen)
1/4 gallon kelp meal (*1 tablespoon)
*Use 1/4 gallon when one part is equal to one
wheelbarrow. Use 1 tablespoon when the measure is
a shovelful.

POTTING MIX

1-1/2 compost
1-1/2 partially decomposed duff
1 used mix
1 sand
1 perlite (or used mistbox mix) or 1/2 perlite (or
used mistbox mix and 1/2 grape seed
1/2 soil

DRYLAND POTTING MIX

3 potting mix
1 sand
1 perlite (or used mistbox mix)
or
1 grape seed

UCSC FIELD SPEEDLING MIX

2 compost (sifted .5 inch screen)
1 coir fiber (premoistened)
1 vermiculite (medium/fine)
3 cups blood meal*
*This amount of blood meal is based on when the
measure of one part is equal to a wheelbarrow.

6-PACK MIX

2 compost
2 used flat mix
1 coir fiber
1 sand

LIQUID SUPPLEMENTAL FERTILIZER

Using watering can, per gallon of water:

1/4 cup liquid fish emulsion
1/2 tsp. Kelp powder

Using foliar sprayer:

Also add 1/4 tsp. sticker-spreader (surfactant),
added last into the tank to avoid excess foaming (see
Resources section)

Mix ingredients in a little water in a bucket, then
pour into a 3-gallon backpack sprayer and fill to the
line with more water. For basal applications, remove
spray nozzle.

Fertigation is best done in the early morning or in
the evening.

Appendix 8: Pricking Out Technique and Depth of Transplanting

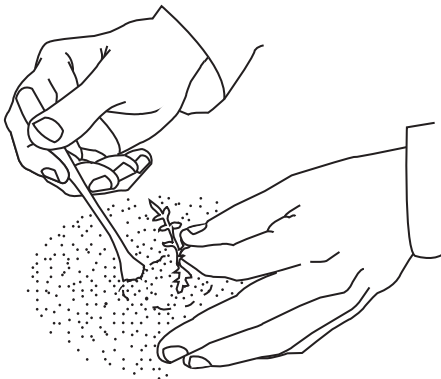

Gently prick out seedling from densely planted flat

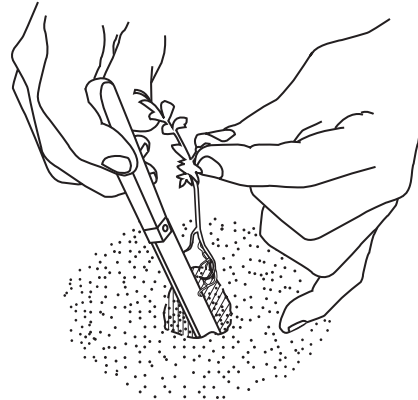

Place seedling in a new flat planted at lower density

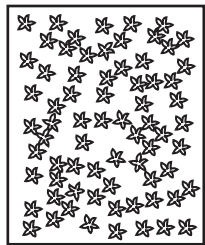

Plants sown at a high density (e.g., 200/flat) are pricked out into several flats at a lower density (e.g., 50/flat) to mature

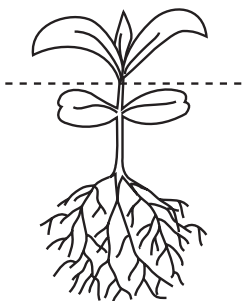
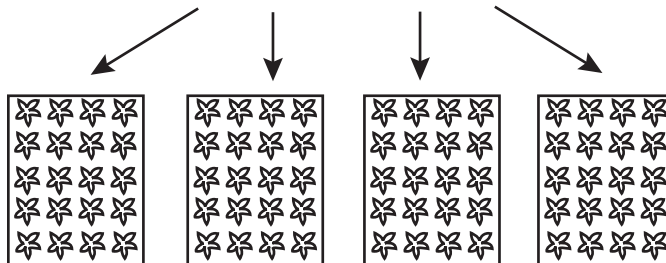

Proper transplanting depth

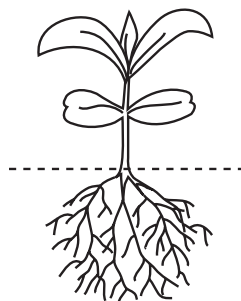
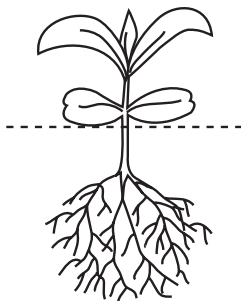

Improper transplanting depth

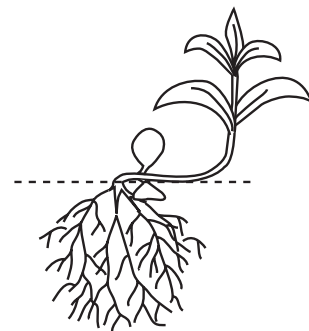

Appendix 9: Flat-Grown and Cell-Grown Seed-

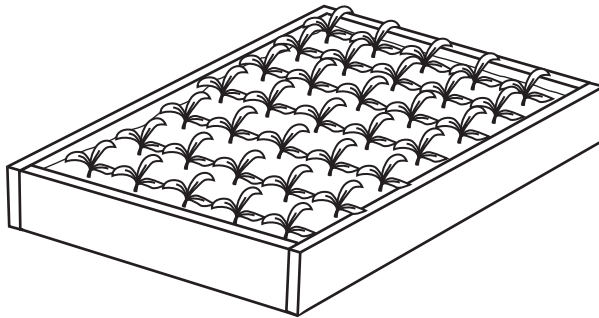

Flat-grown seedlings at transplant maturity —note balance of roots and shoots

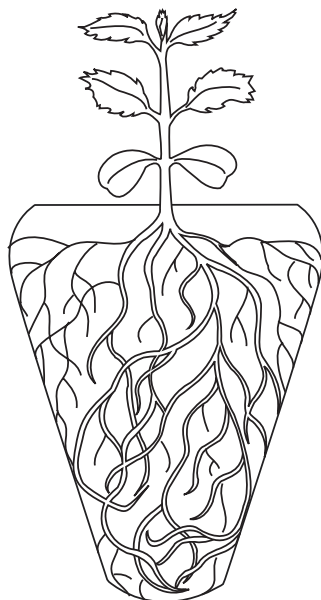
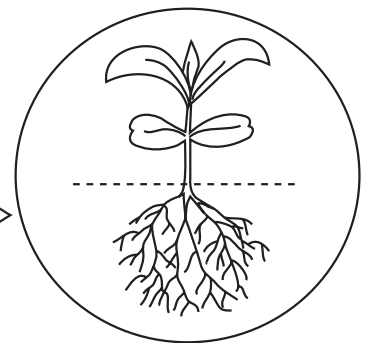
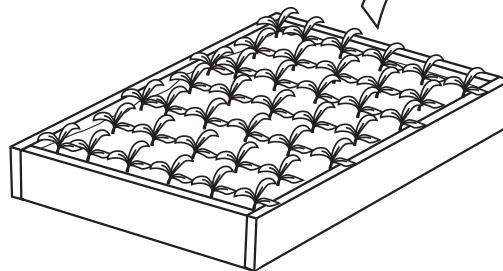

Cell-grown seedling at transplant maturity —note balance of roots and shoots

illustrations by Cathy Genetti Reinhard; not to scale

